

Articulated Boom

AB85RJ

(Rotating Jib)



Snorkel

www.snorkelusa.com

Snorkel AB85RJ

Platform	Machine Dimensions	Performance
Height.....84'6" (26 m)	Stowed Length.....41'2" (13 m)	Power Source.....Gas or Diesel
Size.....36" x 96" (91 cm x 244 cm)	Stowed Height.....9'10" (3 m)	Fuel Capacity.....40 gal (151 L)
Capacity.....500 lbs (227 kg)	Wheelbase.....10' (3 m)	Hydraulic Capacity.....65 gal (246 L)
Construction.....Steel	Width.....8'6" (2.6 m)	Drive Speed
	Ground Clearance.....13" (33 cm)	Elevated.....0.6 mph (0.9 km/h)
	Weight.....38,500 lbs (17,500 kg)	Stowed.....3 mph (4.8 km/h)
	Tire Size.....15 x 625 (16 ply rating)	Gradeability (Theoretical).....45%
		Horizontal Reach.....61'11" (18.9 m)

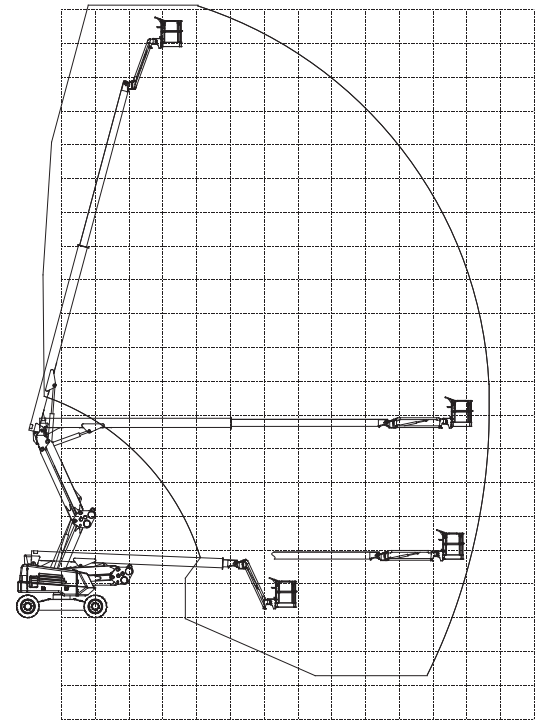
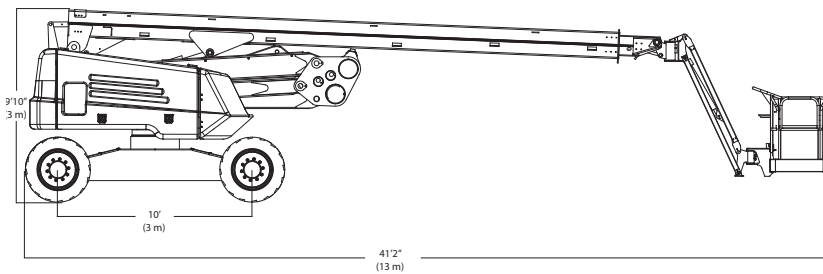

Standard Features

- 360 degree continuous turntable rotation
- Prop. drive, lift, swing, extend & Jib rotate
- Engine anti-restart
- Tie down lugs
- 150 degree hydraulic Platform rotation
- 12 volt emergency operated power
- Manual bleed down valve
- Hydraulic oil level/temp gauges
- Driveable at full height
- Tilt alarm
- 110 volt GFCI AC outlet
- Aluminum upper booms
- Hour meter
- High engine temp/low oil pressure shut down
- Lifting lugs
- Operator Horn
- Four wheel steer
- Four wheel drive
- Foam filled tires

Options

- Platform control box cover
- Flashing light
- Sandblast protection kit
- Driving lights
- Dual Fuel
- Platform work lights
- Cold weather start kit
- Hydraulic Sys. Cold weather Warm-up Kit
- Glazier Package
- Welder in platform
- Drive motion alarm
- Airline to Platform
- AC Generator
- Platform – 30" x 60" (76 x 152 m) Steel 600 lb capacity (272 kg)
- Platform – 30" x 96" (76 x 244 m) Alum 600 lb capacity (272 kg)
- Platform – 30" x 60" (76 x 152 m) Alum 650 lb capacity (295 kg)

DANGER: Models described in this brochure are NON-INSULATED and do not provide electrocution protection from contact with or close proximity to energized conductors which is pointed out on decals and placards attached to the machine. Only qualified and trained operators are to be authorized to use and operate a work platform. Aerial work platforms must be elevated only on firm, level surface. Products in this brochure comply with applicable ANSI Standards. This literature is for illustrative purposes only. Consult Operating Maintenance and Parts Manuals for proper procedures. Specifications may vary and are subject to change without notice or obligation.

Manufacturing Plant
 2009 Roseport Road
 Elwood, Kansas 66024
 800-255-0317
 785-989-3000

Australia
 26 Redfern Road
 Wetheril Park NSW
 2164 Australia
 (02) 9725 4000