

**TB126J**



**Straight Jib  
Boom**

**Snorkel**

[www.snorkelusa.com](http://www.snorkelusa.com)

## Snorkel TB126J

Platform	Machine Dimensions	Performance
Height ..... 126' (38.4 m)	Stowed Length..... 42'9" (13 m)	Power Source..... Gas or Diesel
Size..... 96" x 30" (243.8 cm x 76 cm)	Stowed Height ..... 10'4" (3.2 m)	Fuel Capacity..... 40 gal (151.4 L)
Capacity ..... 500 lbs (227 kg)	Wheelbase..... 12' (3.7 m)	Hydraulic Capacity..... 90 gal (341 L)
Construction..... Aluminum	Width (axles extended) . 12' 10" (3.9 m)	Drive Speed
	Width (axles retracted)..... 8' 6" (2.6 m)	Elevated..... Creep
	Weight..... 42,150 lbs (19,119 kg)	Stowed..... 3 mph (4.8 km/h)
	Tire Size.... 18" x 22.5" (46 cm x 57cm)	Gradeability (Theoretical)..... 42%
		Horizontal Reach..... 63' (19.2 m)

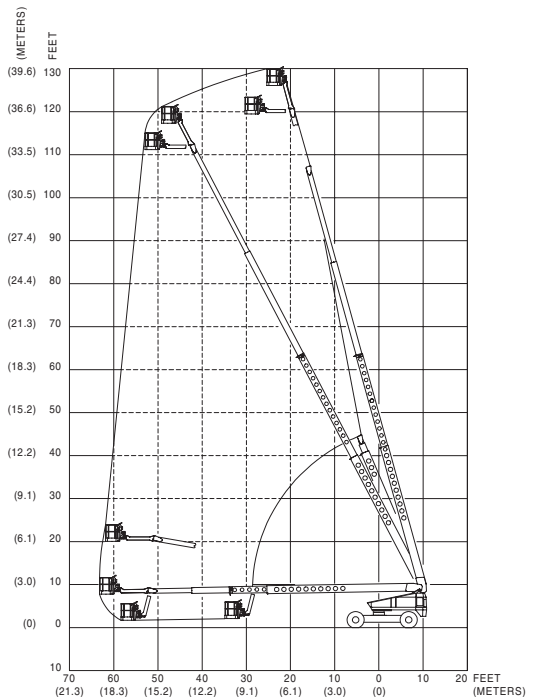
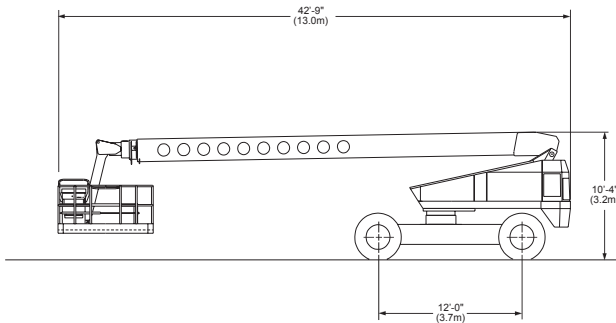

### Standard Features

- Foam filled tires
- Prop. drive, lift, swing, ext. & jib
- Engine anti-restart
- Tie down lugs
- 180 degree hydraulic Platform rotation
- 12 volt emergency operated pwr
- Electric bleed down at chassis
- 4-wheel drive & 4-wheel braking
- Envelope Management system
- Keyed master switch
- Driveable at full height
- Tilt alarm
- 125 volt GFCI AC outlet
- Aluminum upper booms
- Hour meter
- High engine temp/low oil pressure shut down
- Lifting lugs
- Extendable rear axles
- Operator Horn
- Built in chassis jack

DANGER: Models described in this brochure are NON-INSULATED and do not provide electrocution protection from contact with or close proximity to energized conductors which is pointed out on decals and placards attached to the machine. Only qualified and trained operators are to be authorized to use and operate a work platform. Aerial work platforms must be elevated only on firm, level surface. Products in this brochure comply with applicable ANSI Standards. This literature is for illustrative purposes only. Consult Operating Maintenance and Parts Manuals for proper procedures. Specifications may vary and are subject to change without notice or obligation.

### Options

- Platform control box cover
- Flashing light on boom
- Swinging gate
- Sandblast protection kit
- Driving lights
- Platform work lights
- Cold weather start kit
- Drive motion alarm
- Tow kit
- Airline to Platform
- AC Generator
- Hydraulic Sys. Cold weather Warm-up Kit

**Manufacturing Plant**  
 2009 Roseport Road  
 Elwood, Kansas 66024  
 800-255-0317  
 785-989-3000

**Australia**  
 26 Redfern Road  
 Wetheril Park NSW  
 2164 Australia  
 (02) 9725 4000